



TraficCam



4TI



1TI

10-6030/31: TraficCam - revision R6.00
10-6027: 4TI - revision R6.00; 10-6028: 1TI - revision R3.00

TraficCam PC Tool - version V2.03
TraficCam firmware - version V2.10
Interface firmware - version V2.06

TraficCam with 4TI or 1TI

Manual release: June 2009



Safety warning

EN55022

FCC Part 15

Warning

This is a class A product. In a domestic environment this product may cause radio interference in which case the user may be required to take adequate measures.

This device complies with part 15 of the FCC Rules. Operation is subject to the following two conditions: (1) This device may not cause harmful interference, and (2) this device must accept any interference.

Note: This equipment has been tested and found to comply with the limits for a Class A digital device, pursuant to part 15 of the FCC Rules. These limits are designed to provide reasonable protection against harmful interference when the equipment is operated in a commercial environment. This equipment generates, uses, and can radiate radio frequency energy and, if not installed and used in accordance with the instruction manual, may cause harmful interference to radio communications. Operation of this equipment in a residential area is likely to cause harmful interference in which case the user will be required to correct the interference at his own expense.

Modifications not expressly approved by the manufacturer could void the user's authority to operate the equipment under FCC rules.

Notice

The information contained in this document is subject to change without notice.

Traficon n.v. makes no warranty of any kind with regard to this material, including, but not limited to, the implied warranties of merchantability and fitness for a particular purpose.

Traficon n.v. shall not be liable for errors contained herein or for incidental or consequential damages in connection with the furnishing, performance, or use of this material.

No part of this document may be copied, reproduced, or translated to another language without the prior written consent of Traficon n.v.

Copyright © 2009 , Traficon n.v. - All rights reserved

Traficon n.v.
Vlamingstraat 19
B-8560 Wevelgem
Belgium

Tel +32 (0)56 37.22.00
Fax +32 (0)56 37.21.96
E-mail traficon@traficon.com

Table of contents

Introduction	1
About TrafiCam	1
Use of the documentation	1
Hardware	2
The TrafiCam system items	2
System with 4TI as the interface	3
System with 1TI as the interface	3
The TrafiCam sensor	4
The interface	6
The 4TI interface	6
The 1TI interface	7
The cables for connection	8
The accessories for mounting	8
Installation topology	9
Installation	10
Step I: Mount the TrafiCam sensor on a stable pole	10
Step II: Connect the TrafiCam sensor to the interface	11
Step III: Mount the interface by clicking it on the DIN rail	12
Step IV: Connect the interface to the traffic controller	12
Step V: Connect the interface to the PC	12
Maintenance	13
Software installation	14
Install TrafiCam PC Tool	14
Install the interface driver	14
Set the PC port for communication	14
The work area of TrafiCam PC Tool	15
Set up the TrafiCam sensor	17
Edit the presence detection zones	17
Edit the default presence detection zone	18
Add a zone	18
Set the zone to detect stationary vehicles only (stop detection mode)	18
Set the output relation	18
Activate the setup of TrafiCam	18
Configure the interface	21
Assign the outputs of the interface	21
Activate the configuration of the interface	22
Advanced settings	23
The failsafe function	23
Detection Recall	23
Quality Recall	23
The filtering functions	24
Inverse direction suppression	24
Camera movement suppression	24
Tree shadow suppression	24
Reflection suppression	24
Other advanced settings	24
Other functions	26
View the detection	26
View live detection on the whole video image	26
View live detection on a single presence detection zone	26
Set the delay and extend time for a zone	26
Set the vehicle counting function	27
Set the pulse generation function	27
Save or load the setup of a TrafiCam sensor	28
Save a configuration to the PC	28
Load a configuration to the TrafiCam sensor	29
Save or load the configuration of the interface	29

Save the configuration of the interface to the PC.....	29
Load a configuration to another interface.....	30
Upgrade firmware.....	30
Upgrade the interface firmware	30
Upgrade the TrafiCam firmware	30
Change the colour of the zones	30
Hardware specification TrafiCam	31
Hardware specification 4TI.	32
Hardware specification 1TI.	33
Appendix	34
Appendix 1: Lens selection and camera positioning	34
Guidelines for the sensor position	34
The detection area in relation to the camera height and the minimum detection distance.....	35
Appendix 2: Output wiring diagram	37
Appendix 3: Colour code of the cable wires.....	37

1. Introduction

About TrafiCam

TrafiCam integrates both camera and detector in a compact, stylish housing and detects vehicles waiting at or approaching an intersection. In addition, TrafiCam also has a vehicle counting function.

TrafiCam - based on field proven video detection technology - is part of the Traficon product range. Traficon is worldwide recognised as the market leader in traffic video detection.

TrafiCam is easy to install and mount on existing or new infrastructure. Configuration is done via TrafiCam PC Tool. A video image from the sensor allows accurate positioning of multiple presence detection zones. TrafiCam provides an input to the traffic light controller upon presence detection.

Use of the documentation

This user guide describes the installation and setup of a TrafiCam system with 4TI or 1TI as the interface between the TrafiCam sensor, PC and traffic controller.

In addition you can consult the **Quick Reference Card**.

The quick reference card contains basic information about TrafiCam PC Tool and the setup of the TrafiCam sensor.

The TrafiCam website (www.traficam.com) includes a **Setup Tutorial** movie, a list of **Frequently Asked Questions** and other useful information to install and set up a TrafiCam system.

2. Hardware

The TrafiCam system items

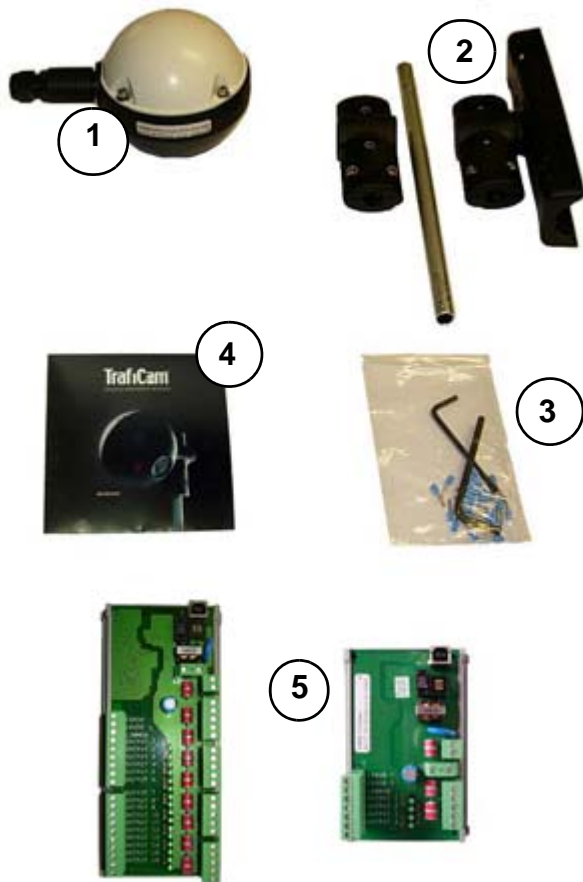

- 1 = The TrafiCam sensor
- 2 = The mounting accessories
- 3 = Tools (hex keys and cable tags)
- 4 = The installation CD
(with the PC tool and the user guides)

- 5 = The interface: 4TI (left) or 1TI (right)

Items of the TrafiCam system

In addition, the installation requires:

- retaining straps
- connection cables (see [The cables for connection](#))
- PSU (12-26 V AC/DC)

TrafiCam with 4TI or 1TI

System with 4TI as the interface

Up to 4 TrafiCam sensors can be connected to the 4TI interface.

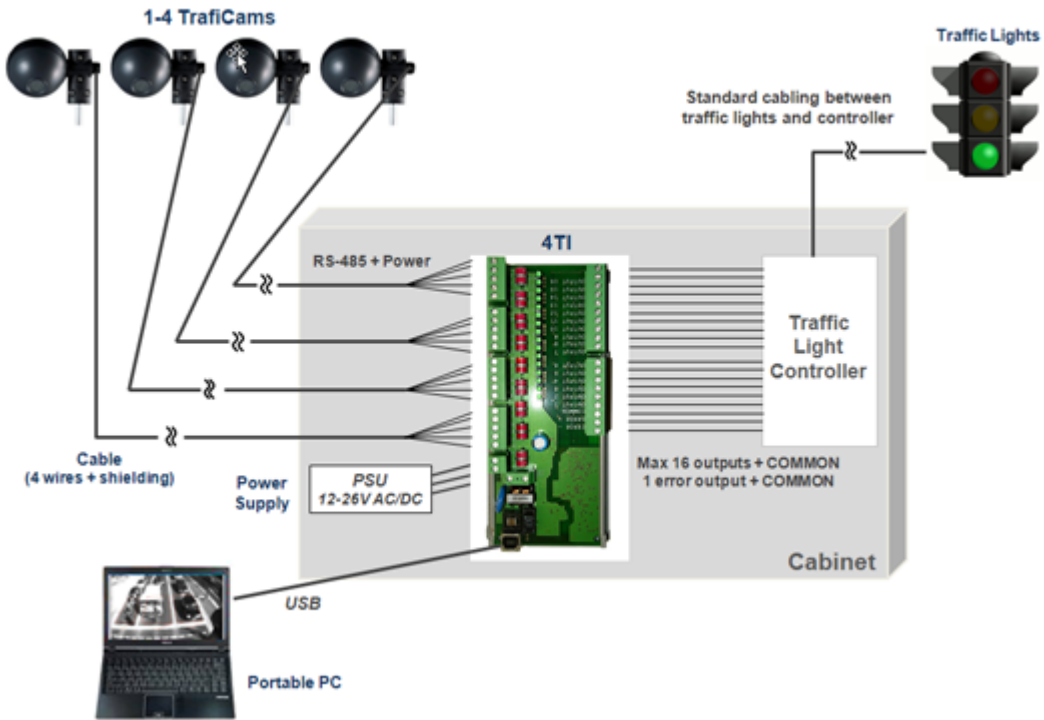

System architecture of the TrafiCam system with 4TI as the interface

System with 1TI as the interface

1TI serves as the interface for 1 TrafiCam sensor.

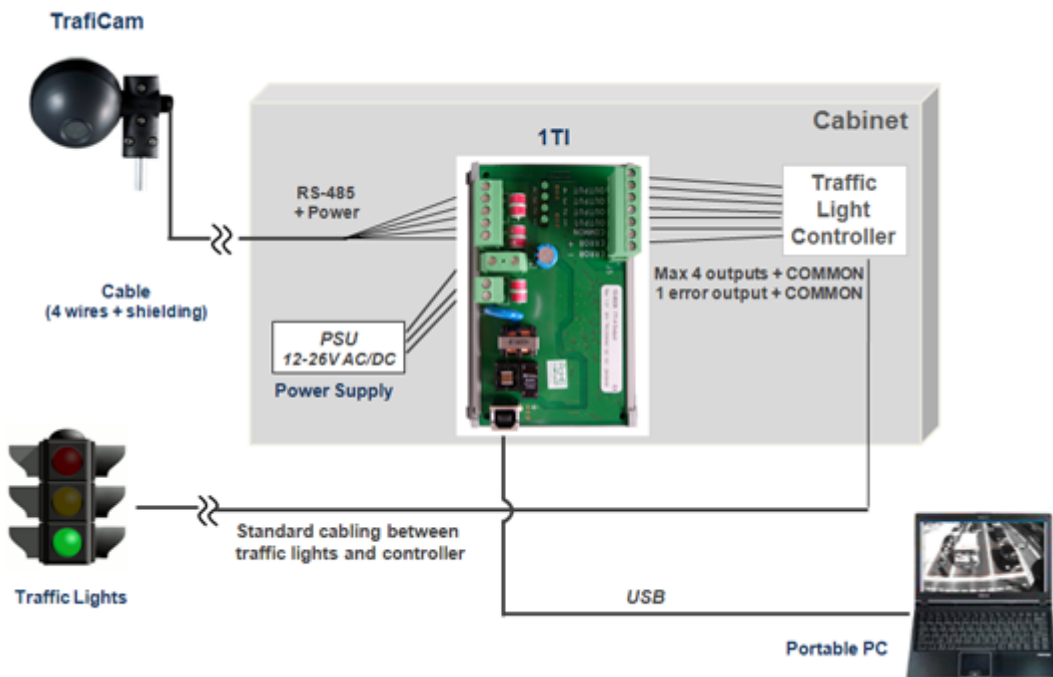

System architecture of the TrafiCam system with 1TI as the interface

TrafiCam with 4TI or 1TI

The TrafiCam sensor

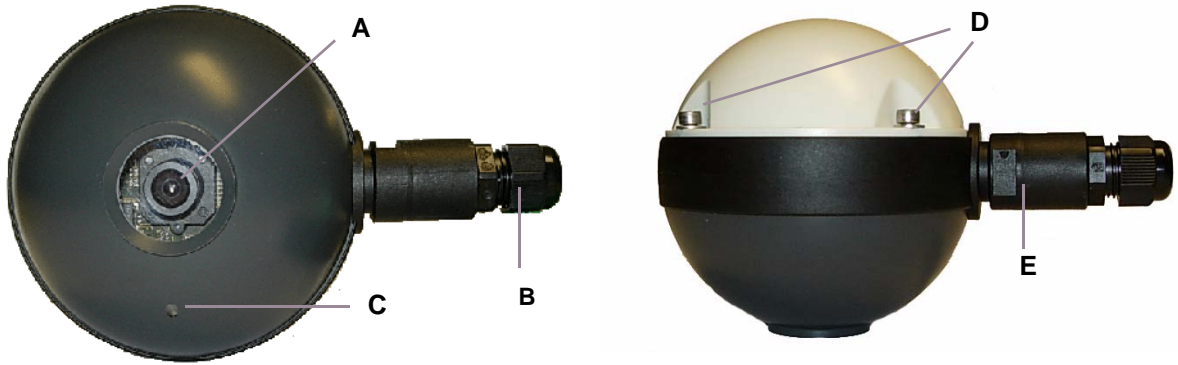

A = The lens

B = The gland to insert the connection cable between sensor and interface

C = The sensor LED

D = The screws on the rear shell (to open the sensor)

E = The rotating point to fix the mounting bracket

Front and side view of the TrafiCam sensor

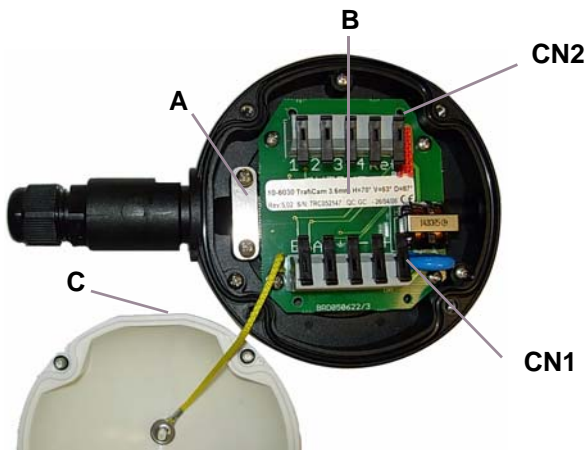

CN1 = The connector to the interface

CN2 (not used)

A = The fixation plate (to keep the connection cable in its place)

B = The product label

C = Flattened side of the rear shell (as an aid to close the sensor)

The TrafiCam sensor opened

TrafiCam with 4TI or 1TI

The tables below illustrate the pinout of the connector CN1 and the indicator code of the TrafiCam LED.

Pinout of connector CN1	
Pin	Description
+	+ Power supply
-	- Power supply
⊥	Grounding
A	RS-485A
B	RS-485B

LED	Indication
On (off)	Vehicle presence detection (no detection)
Flashing	TrafiCam in boot mode
Single flash	Failsafe mode - detection recall
Double flash	Failsafe mode - quality recall
Triple flash	TrafiCam is learning
Off (permanently)	No power

The interface

The 4TI interface

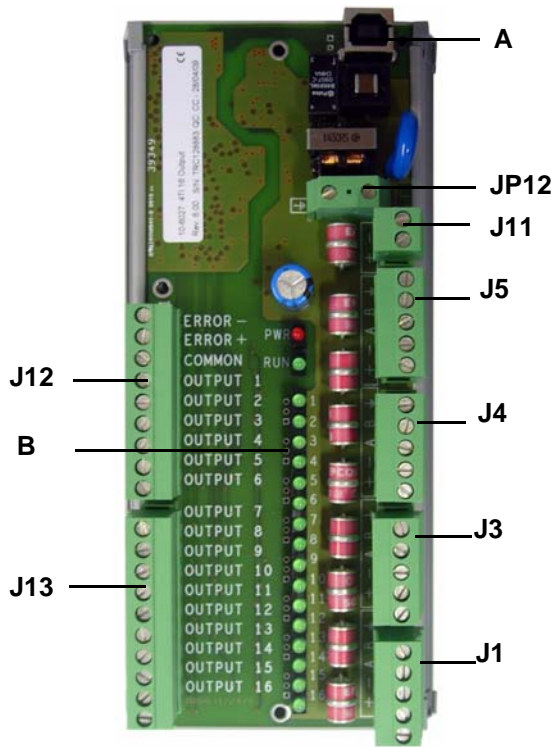

A = The USB-B connector (to connect to the PC)

B = LEDs indicating:

PWR: power supply
 RUN: interface operational
 1-16: output 1 to 16

JP12 = Grounding

J11 = The PSU connector for power supply

4TI can also feed the TrafiCam sensors.

J1, J3, J4 or J5 = The connector to the TrafiCam sensor (maximum 4 sensors)

The connector to the TrafiCam master sensor

J12, J13 = The output connectors to the traffic controller

The tables below provide the pinout scheme of connector J1 to J5, J12 and J13.

The 4TI interface

Pinout of connector J1 (same for connector J3, J4, J5)	
Pin	Description
+	+ Power supply
-	- Power supply
A	RS-485A
B	RS-485B
⏏	Grounding

Pinout of connector J12 and J13	
Pin	Description
Error -	- Error output
Error +	+ Error output
Common	Common output (for output 1 to 16)
Output 1 to 16	Output 1 to 16

The 1TI interface

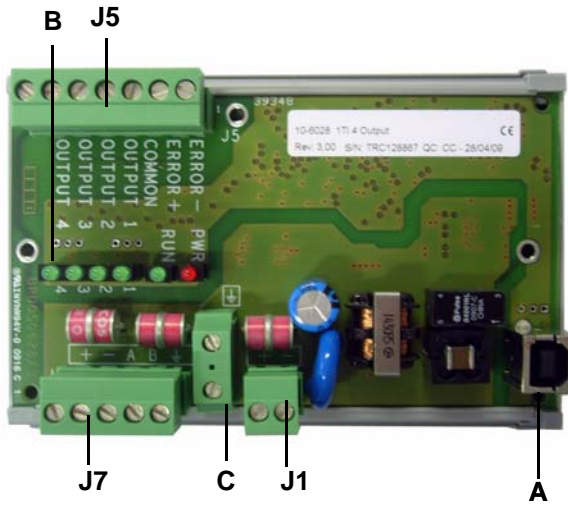

A = The USB-B connector (to connect to the PC)

B = LEDs indicating:

PWR: power supply
 RUN: interface operational
 1-4: output 1 to 4

C = Grounding

J1 = the PSU connector for power supply

1TI can also feed TrafiCam.

J7 = The connector to TrafiCam

J5 = The output connector to the traffic controller

The tables below provide the pinout scheme of connector J5 and J7.



The 1TI interface

Pinout of connector J5	
Pin	Description
Error -	Error output -
Error +	Error output +
Common	Common output (for output 1 to 4)
Output 1 to 4	Output 1 to 4

Pinout of connector J7	
Pin	Description
+	+ Power supply
-	- Power supply
A	RS-485A
B	RS-485B
⏚	Grounding

The cables for connection

The table below gives an overview of the cables used for connecting the TrafiCam sensor, the interface and the PC.

Connection	Cable	Illustration
Sensor to interface	UV-resistant, 4 wires + shielding STP, cable d. 5-9,2 mm, min. 2x2 + shield min. wire d. 0,3 mm	
Interface to PC	USB cable type USB-A/USB-B	

The cables for connection

The accessories for mounting

There is a mounting bracket for the TrafiCam sensor and a mounting bracket to the pole. The tube connects both brackets.

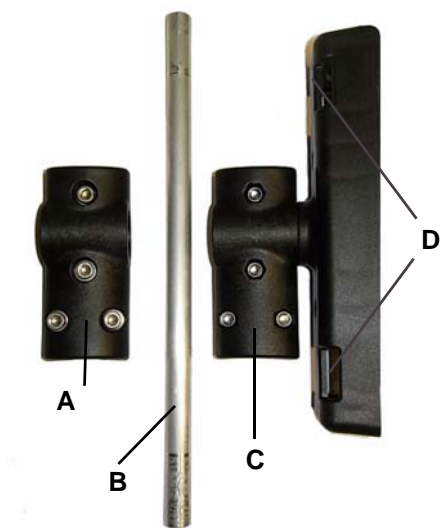

- A** = The mounting bracket for the TrafiCam sensor
- B** = The tube
- C** = The mounting bracket to the pole
- D** = The holes to put the retaining straps through

The mounting accessories (brackets and tube)

3. Installation topology

This applies only to a hardwired system with 4TI as the interface.

4TI serves as the interface for up to 4 TrafiCam sensors. Connect the TrafiCam sensors to the interface in a star or a bus topology or a combination of both.

Star topology	Each TrafiCam sensor is connected directly to 4TI.
Bus topology	All TrafiCam sensors are connected in sequence. One sensor is connected to 4TI.
Combined star-bus topology	See figure below.

The **maximum interconnection length** between TrafiCam and 4TI is **200 m**.

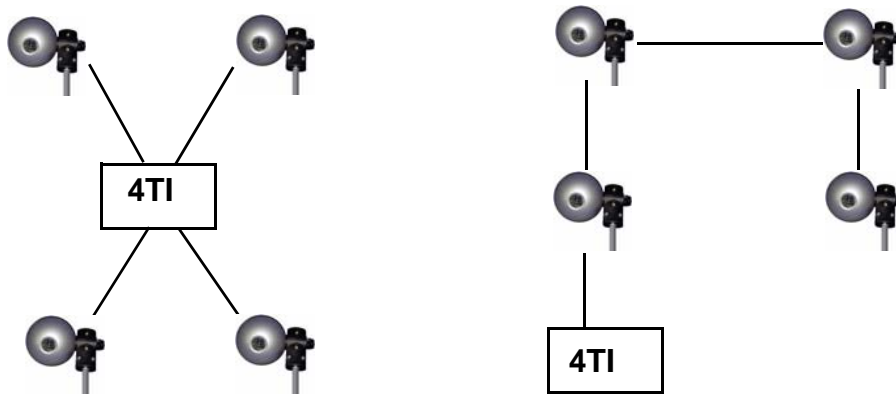

Star topology (left) and bus topology (right)

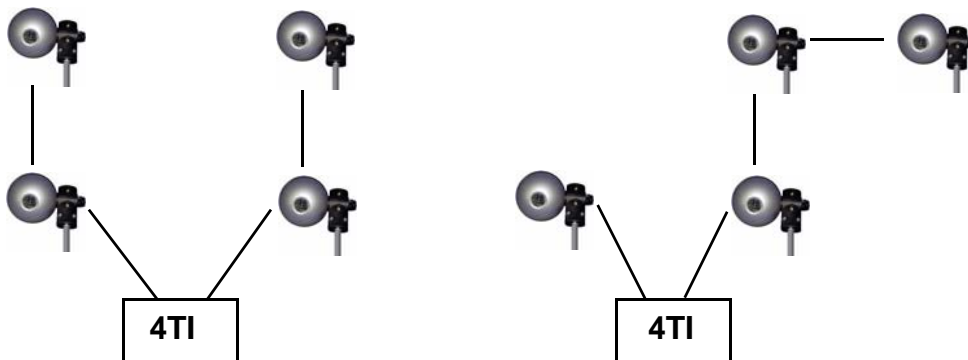

Combined star-bus topology

4. Installation

Do **not remove the lens cover** until TrafiCam is installed.

Ensure that **the system power is off** before starting the installation.

Step I: Mount the TrafiCam sensor on a stable pole.

- Fix the mounting tube to the brackets (Torque max = 1,3 Nm). **(1)**
- Fix TrafiCam to the pole using retaining straps. **(2)**
Put the retaining straps through the holes in the bracket.
- Position TrafiCam provisionally (Torque max = 1,3 Nm). **(3)**
You can mount TrafiCam in a horizontal or vertical position.
TrafiCam is a downward looking device.

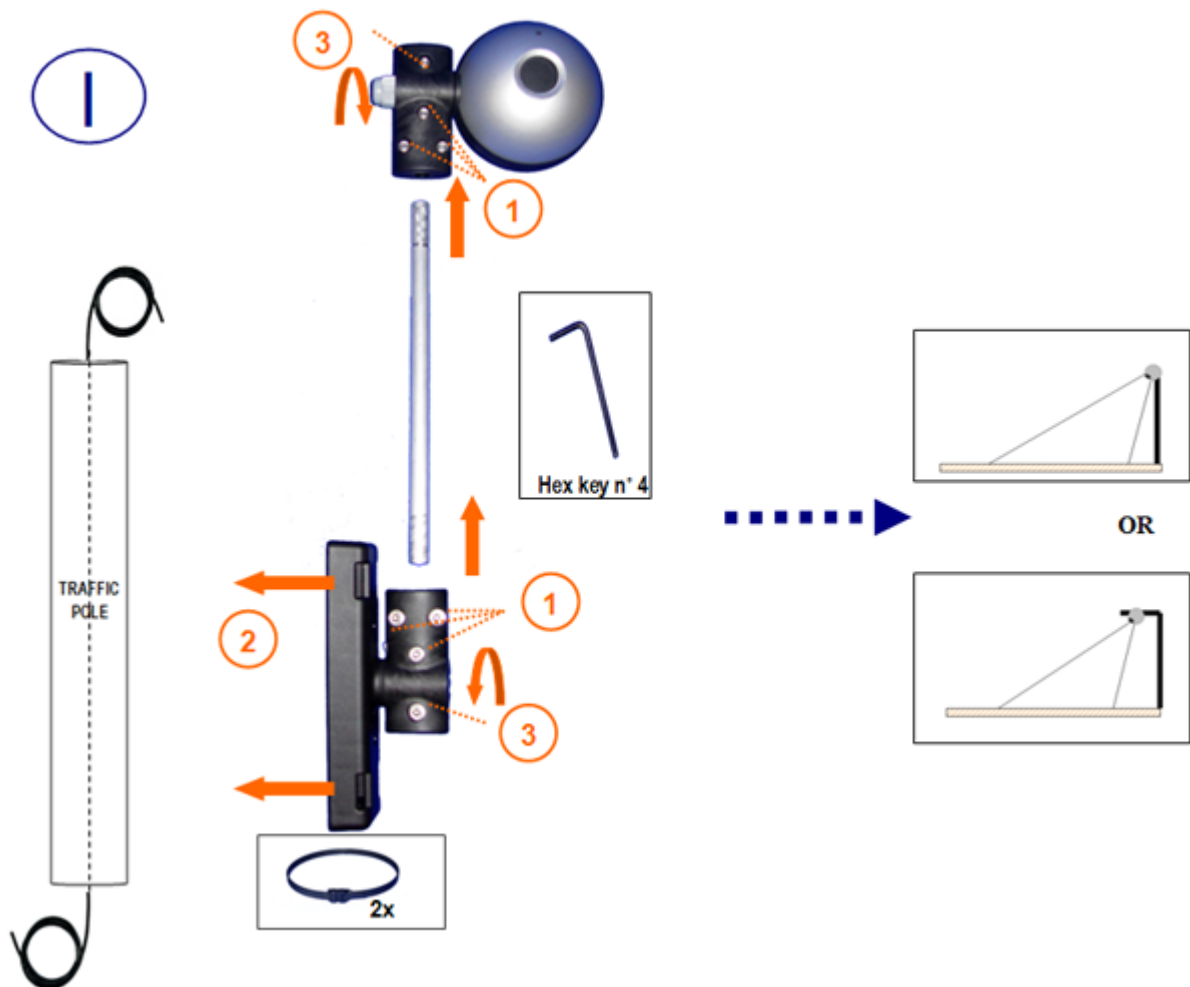

Step II: Connect the TrafiCam sensor to the interface.

Use a shielded twisted pair cable, UV-resistant, 4 wires+shield.

At the TrafiCam side:

- Open the sensor. (1)
- Loosen the cable gland. (2)
- Insert the cable into TrafiCam through the gland. (3)
- Strip the wires and fix the cable tags. Isolate the grounding wire. (4)
- Connect the cable to CN1 and fix the cable plate. (5)
- Close TrafiCam (Torque max = 1,0 Nm). (6)
- Tighten the cable gland. (7)

At the interface side: (8)

- For 4TI: connect the cable to the connector J1 (or J3, J4, J5).
- For 1TI: connect the cable to the connector J7.

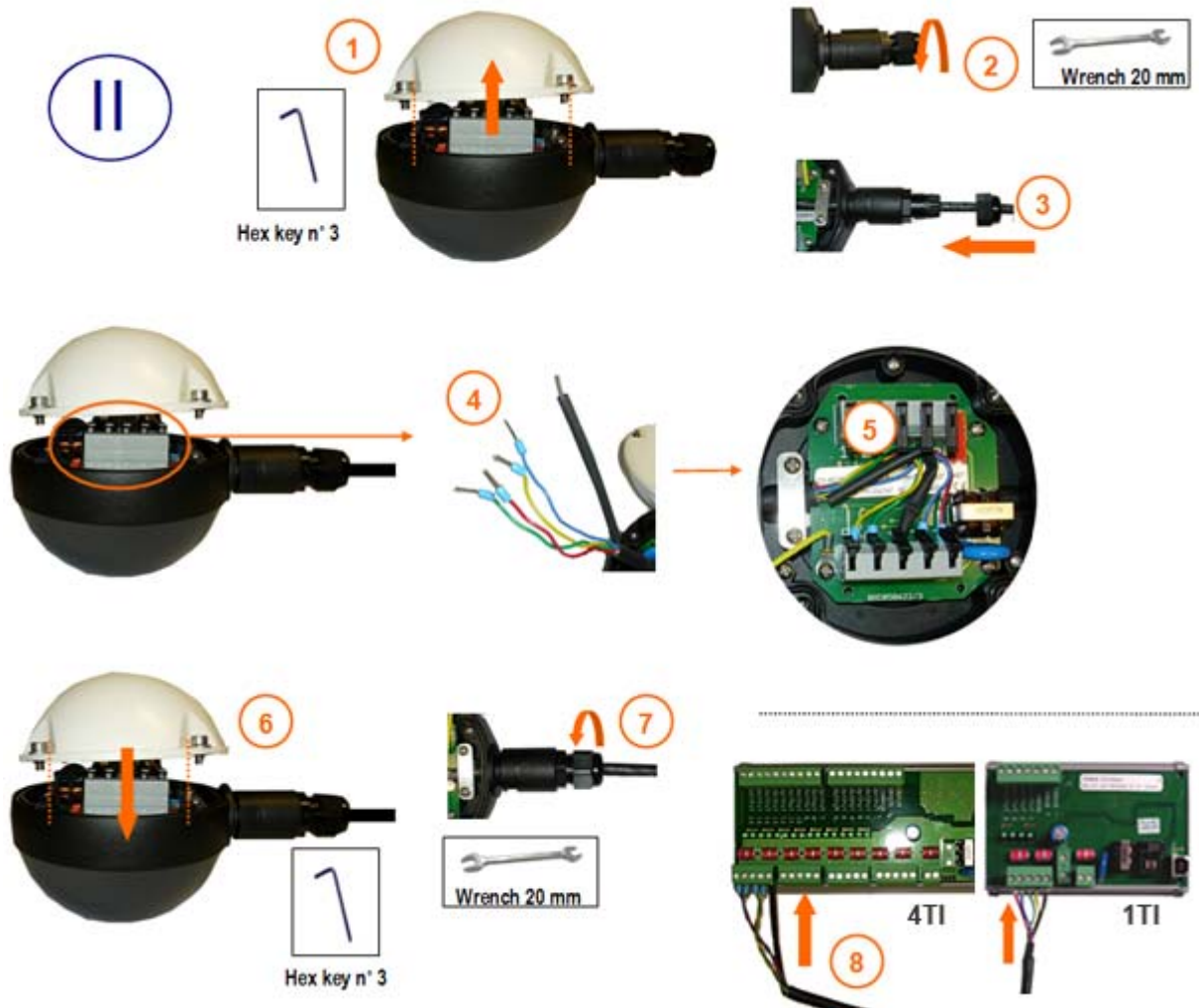

Step III: Mount the interface by clicking it on the DIN rail.

Step IV: Connect the interface to the traffic controller.

Step V: Connect the interface to the PC.

Use a USB cable type USB-A/USB-B.

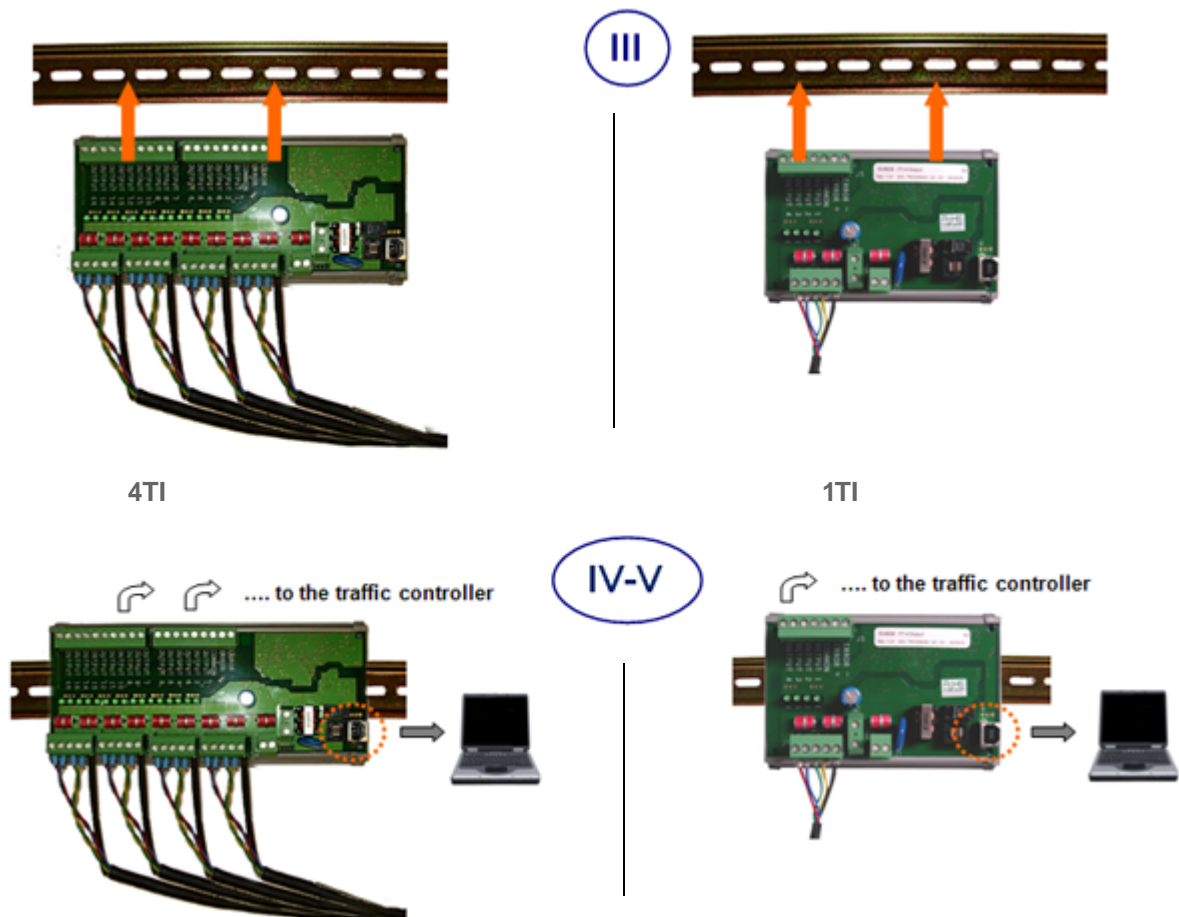

Finally connect the power supply and remove the TrafiCam lens cover.

You **optimise the position** of TrafiCam via visual verification (TrafiCam PC Tool, see next). Always verify that there is no horizon in the image!

Tighten all screws after optimising the position of TrafiCam.

5. Maintenance

The maintenance of TrafiCam can be done during the regular maintenance of the traffic lights and controller.

Instruction	Frequency	Tools	Remark
Clean the faceplate of TrafiCam.	Once per year	Soft cloth and mild detergent	Avoid movement of TrafiCam.
Check the camera image. Verify the configuration of the system.	Once per year	PC with TrafiCam PC Tool	Use the setup manual for guidance.

Depending on the on-site conditions you may need to increase the frequency of maintenance.

6. Software installation

TrafiCam and 4TI or 1TI are set up with TrafiCam PC Tool. This PC tool is available from the installation CD delivered with TrafiCam.

First you install TrafiCam PC Tool, then you install the interface driver.

Install TrafiCam PC Tool

- Insert the TrafiCam **installation CD** in the CD-ROM drive.
- Go to the installation of TrafiCam PC Tool.
- Follow the instructions provided by the installation wizard.
- Click **Finish** to complete the installation.

Install the interface driver

Upon first connection of the interface to the PC the **Found New Hardware Wizard** appears.

- Select **Yes, this time only**.
- Click **Next**.
- Follow the recommended instructions provided by the wizard.
- Click **Finish** to close the wizard.

Set the PC port for communication

- Start TrafiCam PC Tool.
- Select **USB** as the communication port.
- Click **Retry**.

7. The work area of TrafiCam PC Tool

TrafiCam PC Tool has 2 modes:

- the sensor mode: to set up the TrafiCam sensor
- the interface mode: to configure the interface.

TrafiCam PC Tool is started in the interface mode. This mode displays an image of all TrafiCam sensors connected to the interface. Click **Go to...** to switch to the sensor mode.

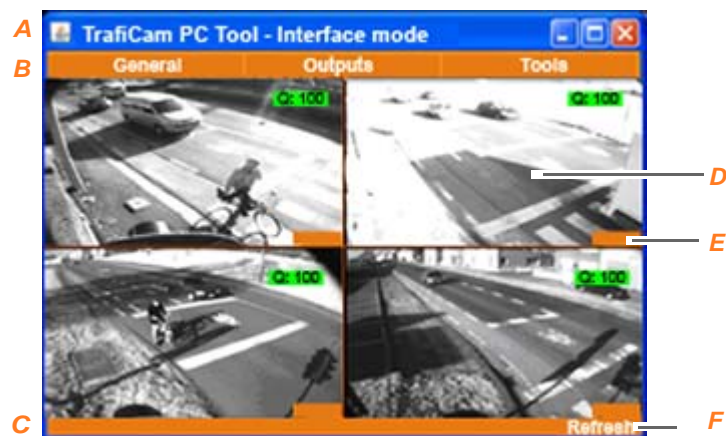

TrafiCam PC Tool - Interface mode (4TI)

- A:** Title bar with PC tool mode **B:** Menu bar **C:** Status bar
D: the TrafiCam sensor image with indication of the communication quality (communication between sensor and interface)
E: the **Go To** button (with sensor number and name)
F: the **Refresh** button

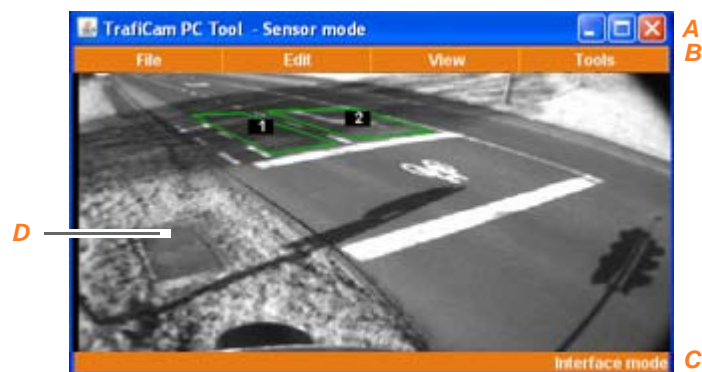

TrafiCam PC Tool - Sensor mode

- A:** Title bar **B:** Menu bar **C:** Status bar **D:** the TrafiCam sensor image
1, 2: the vehicle presence detection zones

How to	Description
Open a menu or submenu	Click the menu item. A submenu is indicated via an arrow ▶ . Close a menu by clicking outside the menu.
Activate a function	Click the function.
Select a menu item	Put the cursor on the menu item.
Set a parameter for a menu item	Put the cursor on the menu item. Use the arrow keys or the mouse scroll wheel to make the selection.
Refresh the sensor image	Click Refresh in the bottom right corner in the interface mode.
Set the language	Select the language from the General menu in the interface mode.
Go to the sensor mode	Click Go to ... (E) in the bottom right corner of the sensor image in the interface mode.
Return to the interface mode	Click Interface mode in the bottom right corner in the sensor mode.

Basic functions in TrafiCam PC Tool

8. Set up the TrafiCam sensor

Edit the presence detection zones

A zone can have 3 possible functions (detection modes):

- **Presence:** presence detection of moving and stationary vehicles (= default function)
- **Stop:** presence detection of stationary vehicles
- **Loop:** Vehicle counting
See [Set the vehicle counting function](#).

A zone is displayed according to its detection mode.

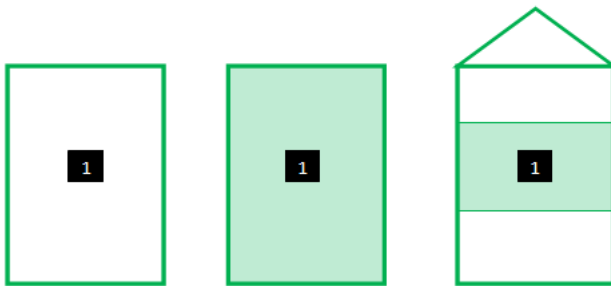

Zone displayed according to its detection mode: presence (left), stop (middle) and loop (right)

You work in the sensor mode of TrafiCam PC Tool to set up the TrafiCam sensor.

- Click the **Go To x: {TrafiCam}** button in the interface mode of TrafiCam PC Tool to switch to the sensor mode. The factory default setup of the TrafiCam sensor is displayed when you first open TrafiCam PC Tool in sensor mode. This default configuration has one presence detection zone.

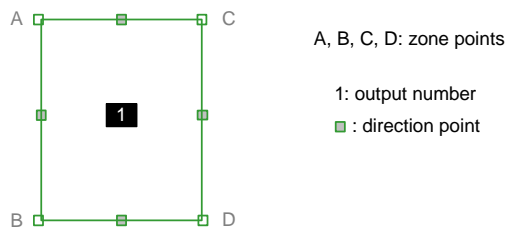

Presence detection zone with zone points and direction points

Note: To start a new setup from default factory settings: click **New Configuration** from the File menu.
If you wish to modify the setup of the TrafiCam sensor: click **Get Configuration** from the File menu.

Edit the default presence detection zone

The **Guidelines to edit the zones** illustrate the advised size and position of a presence detection zone.

- Click-and-drag anywhere in the zone to **move** the zone.
- Put the cursor on a zone point.
- Click-and-drag the zone point to position it.
- Position the other zone points accordingly.

The zone should be made direction sensitive only in situations where vehicles in the opposite direction may cause unwanted detection.

- Double-click the direction point to **define the direction** of the zone.
If you wish to delete the zone direction: double-click the direction point.

TrafiCam PC Tool **assigns an output** to the zone automatically. The number in the zone refers to the assigned output. To change the assigned output: right-click the zone and select an output from the drop-down menu.

A zone is characterised by its **Zone ID**. To verify the zone ID: right-click the zone, the zone ID is displayed.

Add a zone

- Right-click anywhere on the sensor image except on a zone.
- Click the **Add Zone** pop-up.
- Edit the zone as described previously.

You can place **up to 8 presence detection zones**.

To delete a zone: right-click the zone and click the **Delete Zone** pop-up.

Set the zone to detect stationary vehicles only (stop detection mode)

- Choose **Tools > Advanced Settings > Zone information**.
- To set all zones: click **All Zones** and select **Stop** as the **Detection Mode**.
- To set one zone: select the zone and select **Stop** as the **Detection Mode**.

Set the output relation

You assign an OR or AND relation to the TrafiCam outputs:

- **OR**: the output changes status when presence is detected on **at least one zone** of the output.
- **AND**: the output changes status when presence is detected on **all zones** of the output.
- Select **Outputs** from the Edit menu.
- Select **Output Relation**.
- Use the arrow keys to set the output relation.
Default: Or
Selection: Or, And

Activate the setup of TrafiCam

- Click **Send Configuration** from the File menu.
The configuration is sent to the TrafiCam sensor. This process is displayed in the status bar. After sending TrafiCam PC Tool requests and displays the parameters of the activated setup.

TrafiCam with 4TI or 1TI

TrafiCam starts a learning cycle. The learning cycle takes a few minutes. During the learning cycle all presence detection zones are active and the outputs change their status accordingly.

When you View the detection a message will indicate that TrafiCam is learning. After the learning cycle the system becomes operational.

After you have set up the TrafiCam sensor(s) connected to the interface you continue the setup of the interface (Assign the outputs of the interface).

Guidelines to edit the zones

ALWAYS VERIFY THAT THERE IS NO HORIZON IN THE IMAGE!

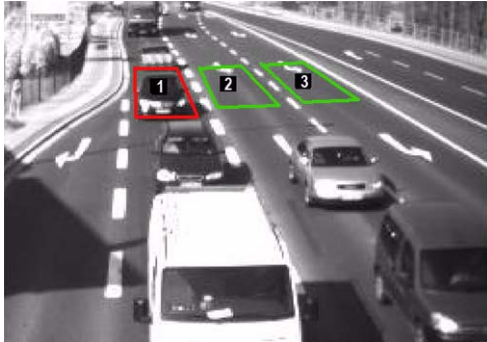

SIZE AND POSITION OF THE ZONE

The zone should have the length and the width of a regular vehicle.

For detection at the stop bar place the zone as such that the vehicle will stop in the middle of the zone.

Take into account that vehicles may stop well in front of or over the stop line.

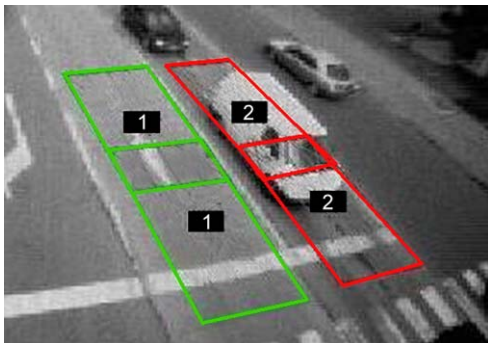

OVERLAPPING ZONES

To optimise detection, two overlapping zones may be used. These zones are assigned to the same output.

Overlapping zones minimize the chance that a car stops in front or behind a zone.

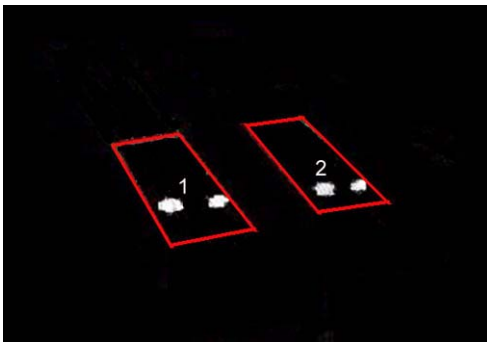

DETECTION AT NIGHT

The detection zones should cover the headlights in every situation.

At night the detection is on the headlights of the vehicle.

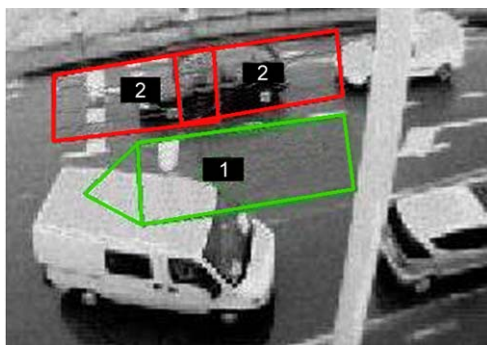

DIRECTION SENSITIVITY

The zone should be made direction sensitive in situations where vehicles in the opposite direction may cause unwanted detection.

9. Configure the interface

You work in the interface mode of TrafiCam PC Tool to configure the interface.

When you start TrafiCam PC Tool, all sensors that are connected to the interface appear after an automatic search by the interface. In case you have exchanged sensors or you have added a sensor to the system it is required to perform a new search: click **Search for TrafiCams** from the General menu.

Always verify that all sensors connected to the interface have the same firmware version.

Assign the outputs of the interface

- Select **Assign Outputs** from the Outputs menu.
- Select the TrafiCam sensor.
- Use the arrow keys to select the interface output for each TrafiCam sensor output.

Example: The zone with output 1 of TrafiCam 1 is linked to output 01 of the interface (4TI: top and 1TI: bottom).

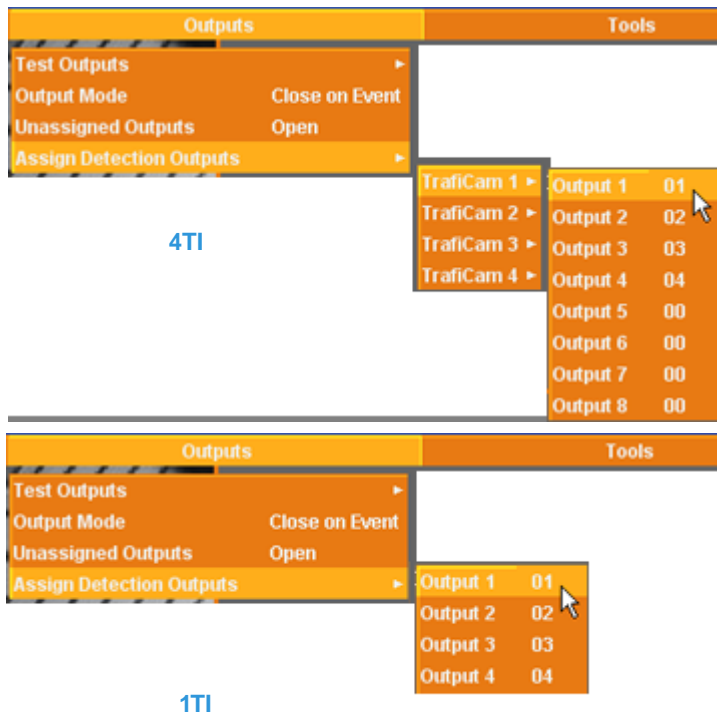

Both the assigned and the unassigned outputs will close upon presence detection. If you wish to change the output mode, proceed as follows:

Change the output mode of the assigned outputs

- Select **Output Mode** from the Outputs menu.
- Use the arrow keys to set the mode.
Default: Close on Event
Selection: Close or Open on Event

Change the output mode of the unassigned outputs

- Select **Unassigned Outputs** from the Outputs menu.
- Use the arrow keys to set the mode.
Default: Close
Selection: Close or Open

Note: TrafiCam PC Tool allows to test the outputs of the interface.

- Select **Test Outputs** from the Outputs menu.
- Click to select the output you wish to test.

The corresponding LED on the interface lights up and the output changes status. The output reacts normal again when you close the Test Outputs menu.

Activate the configuration of the interface

- Click **Send Configuration** from the General menu.

The configuration is sent to the interface. This process is displayed in the status bar. After sending TrafiCam PC Tool requests and displays the parameters of the activated configuration. The system becomes operational.

10. Advanced settings

The advanced settings of the TrafiCam sensor are either not activated or a default value is assigned. Depending on specific local situations modifications may be useful. Please contact your supplier before changing the advanced setup parameters.

Advanced settings include the following functions:

- The failsafe function (detection and quality recall)
- The filtering functions (suppression of unwanted detection caused by wrong-way drivers, camera movement, tree shadows or light reflection)

Note: Output pulse information, zone information and zone colours are described in [Other functions](#).

Proceed as follows to change the advanced settings:

- Verify that you work in the sensor mode of Traficam PC Tool.
- Select **Advanced Settings** from the Tools menu.
- Select a parameter.
- Use the arrow keys to set the parameter.
Parameters, description and settings are described hereafter.

The failsafe function

TrafiCam has a failsafe function (or recall) related to detection and a failsafe function related to quality (detection recall and quality recall). The recall status is indicated via a pop-up when you view the detection (see [View the detection](#)).

Detection Recall

All outputs assigned to recall will change status when there are no vehicles detected during a period defined by the recall activation delay. The moment a vehicle is detected again on one of the zones, the recall status is deactivated.

Assign Recall Function

Default: Enabled

Selection: Disabled, enabled

Recall Activation Delay

Default: 60 min

Selection: --, 1 to 999 min

Quality Recall

All outputs assigned to recall will change status when the quality (image or detection quality) decreases below a set threshold. With a lower threshold the camera is less sensitive for a decreasing image or detection quality. You also set the delay time for (de)activation of the recall status. The image and detection quality parameters are displayed when you [View the detection](#).

Image Quality / Detection Quality Threshold

Default: 4

Selection: 0 to 10

Quality Time Out

Default: 4 min

Selection: 1 to 99 min

The filtering functions

Inverse direction suppression

This function avoids that wrong- or sideways traffic causes unwanted detection. Inverse direction suppression applies to direction sensitive zones only. You set the sensitivity of the suppression function and the delay time for the activation of an inverse direction event.

Inverse Direction Suppression Time

Default: 10 s
Selection: 1-30 s

Inverse Direction Sensitivity

Default: Low
Selection: Low, High

Camera movement suppression

This function avoids unwanted detection in a situation where TrafiCam is moving (mounted on a pole that may be swinging because of the wind). You set the level of suppression. A high level may reduce the detection sensitivity.

Mode

Default: Off
Selection: On, Off, Day, Night

Level

Default: Low
Selection: Low, Medium, High

Tree shadow suppression

This function avoids unwanted detection caused by continuously moving shadows over the image.

Default: Disabled
Selection: Disabled, Enabled

Note: You should set one type of suppression only: camera movement **or** tree shadow suppression. Do not activate both suppression functions simultaneously.

Reflection suppression

This function suppresses unwanted detection caused by the reflection of headlights. Reflection suppression applies only to situations with overhead position of TrafiCam **and** advance presence detection on upcoming traffic. You set the maximum duration of reflection suppression; after that period, detection will be activated.

Mode

Default: Off
Selection: On, Off

Presence Time On

Default: 60 s
Selection: 1-999 s

Other advanced settings

Presence Time Off

This parameter defines the maximum delay time for deactivation of the presence detection. By default it is set to 4 minutes since intersection cycle lengths rarely exceed this time.

The zone will relearn when presence is detected for a duration longer than the Presence Time Off parameter. You only change this parameter when the cycle length of the intersection is not standard.

TrafiCam with 4TI or 1TI

Default: 240 s
Selection: 10-600 s

Detection LED

You can stop the indicator function of the detection LED.

Default: Enabled
Selection: Disabled, Enabled

11. Other functions

View the detection

TrafiCam PC Tool allows to view live detection on the whole video image or on a single presence detection zone. Traficon recommends to use this function only for diagnostic purposes; viewing live detection may reduce the performance of the TrafiCam sensor.

View live detection on the whole video image

- Verify that you work in the sensor mode of TrafiCam PC Tool.
- Click **View Detection** from the View menu.
You view detection on the whole image.

View live detection on a single presence detection zone

- Verify that you work in the sensor mode of TrafiCam PC Tool.
- Click the detection zone.
- Click **View Detection** from the View menu.
You view detection on the presence detection zone. The rest of the video image does not change.
To stop viewing: click **Refresh Image** from the View menu.

Also the following information is displayed when you view live detection.

<p><i>Display:</i></p>  <p>day night</p> <p>Im Q: 10</p> <p>Det Q: 10</p> <p>Comm Q: 100%</p>	<p>Information:</p> <p>Detection mode</p> <p>Quality (image and detection quality, see The failsafe function)</p> <p>Optimum quality = 10</p> <p>Communication quality (between sensor and interface)</p>
---	--

Set the delay and extend time for a zone

TrafiCam allows to define a delay time and an extend time for each presence detection zone.

The delay time is defined as the time between presence detection and the status change of the output. When a vehicle enters the zone the output is delayed until the delay time expires.

The extend time is the time between the moment when the vehicle leaves the zone and the moment when the output from that zone expires. If another vehicle enters the detection zone before the extend timer times out, the detection is held and the extend timer is reset. When the extend timer times out the delay timer has to expire before another presence detection can be received.

Via the extend mode, you can set the extension of presence detection during day or night only.

TrafiCam with 4TI or 1TI

- Verify that you work in the sensor mode of TrafiCam PC Tool.
- Select **Advanced Settings** from the Tools menu.
- Select **Zone Information**.
- Select **All Zones...** if you wish to set the extend and delay time for all zones.
To set the extend and delay time per zone: select a zone from the list.
- Use the arrow keys to set the **Extend Mode**, the **Delay Time** and **Extend Time**.
Default: on (Extend mode)
Selection: on, day, night
Default: 0 s (Delay and Extend Time)
Selection: 0-99,9 s
- Click **OK**.

Set the vehicle counting function

TrafiCam provides a vehicle counting function based on pulses which are sent to the controller. The number of pulses corresponds with the number of vehicles, the length of the pulse indicates the zone occupancy.

Traficon advises to use the vehicle counting function only when the TrafiCam sensor is mounted in a rather vertical position with presence detection in the area close to the camera (see also [Appendix 1: Lens selection and camera positioning](#)).

For vehicle counting, a detection zone configured in loop mode is required. This zone is similar to a presence detection zone (see [Edit the default presence detection zone](#)). You edit the zone as a presence detection zone and an output is assigned. However a loop mode zone must have a direction.

A presence detection zone and a loop mode zone function independently. You can place a loop mode zone over a presence detection zone.

The maximum number of zones (presence and loop mode) is limited to 8.

- Verify that you work in the sensor mode of TrafiCam PC Tool.
- Select **Advanced Settings** from the Tools menu.
- Select **Zone Information** and select a zone from the list.
To set all zones as loop mode zones: select **All Zones...** from the list.
- Set the detection mode to **Loop**.
This zone will now function as a vehicle counting zone.

Note: Verify that all zones configured in loop mode have a direction. You can not send the configuration to the sensor if one or more loop mode zones do not have a direction.

Set the pulse generation function

This function applies to presence detection zones only.

TrafiCam can send pulses to the controller during presence detection.

You define the pulse mode, pulse time, the delay time and the pulse period. The generation of pulses as a function of these parameters is illustrated hereafter.

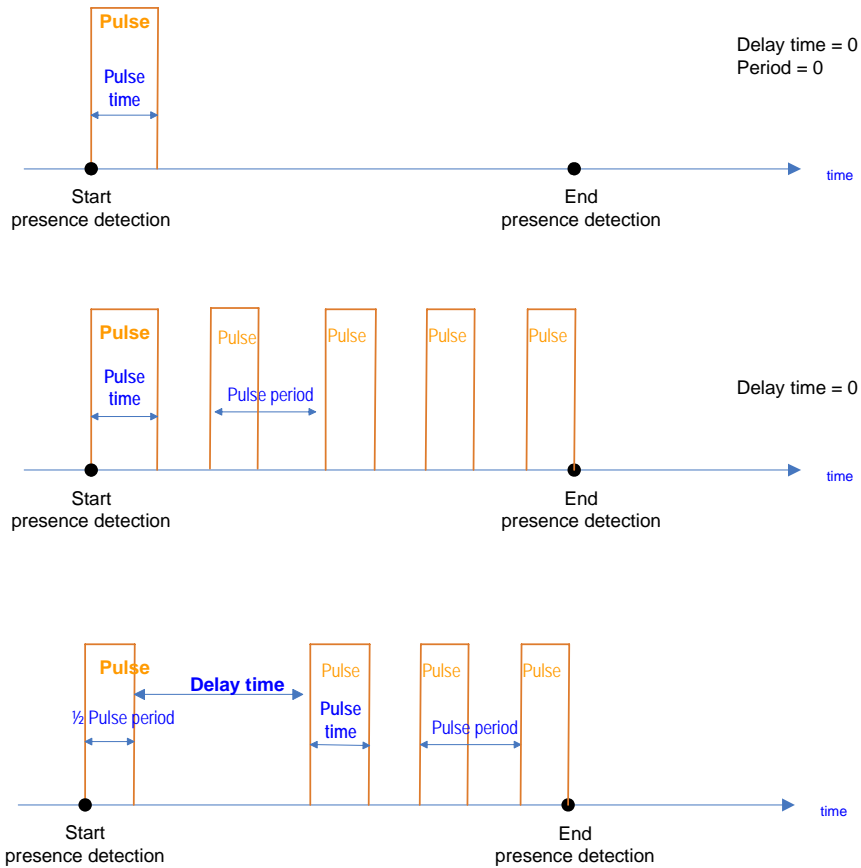

Pulse generation function

- Verify that you work in the sensor mode of TrafiCam PC Tool.
- Select **Advanced Settings** from the Tools menu.
- Select **Output Pulse Information**.
- Select **All Outputs...** if you wish to set the pulse generation parameters for all zones.
To set the pulse generation parameters per zone: select an output from the list.
- Use the arrow keys to set the **Pulse Mode**, the **Pulse Time**, the **Delay Time** and the **Pulse Period**.
Default: none (Pulse mode)
Selection: none, entry, exit
Default: : 4,0 s (Pulse time)
Selection: 0,1-99,9 s
Default: 0 s (Delay time)
Selection: 0-99,9 s
Default: 0,0 (Pulse period)
Selection: 0,0-9,9 s
- Click **OK**.

Save or load the setup of a TrafiCam sensor

You can save the complete setup of the TrafiCam sensor as an XML file for backup purposes, for electronic exchange or to copy the setup to another TrafiCam sensor.

Save a configuration to the PC

After you have set up the TrafiCam sensor in the sensor mode of TrafiCam PC Tool:

TrafiCam with 4TI or 1TI

- Click **Save As...** from the File menu.
- Specify a file name and location.
- Click **Save**.

The configuration is saved as an XML file on to the PC.

Load a configuration to the TrafiCam sensor

- Verify that you work in the sensor mode of TrafiCam PC Tool.
- Click **Open...** from the File menu.
- Select the XML file.
- Click **Open**.

TrafiCam PC Tool displays the loaded configuration.

You modify the setup first or you activate this configuration for the TrafiCam sensor:

- Click **Send Configuration** from the File menu.

TrafiCam starts a learning cycle. The learning cycle takes a few minutes. During the learning cycle all zones are active and the outputs change their status accordingly.

Save or load the configuration of the interface

You can save the configuration of the interface as an XML file for backup purposes, for electronic exchange or to copy the setup to another interface. In addition an overview file is generated including a video image from each TrafiCam sensor connected to the interface and an overview table of all assigned outputs.

Save the configuration of the interface to the PC

After you have set up the interface in the interface mode of TrafiCam PC Tool:

- Click **Save As...** from the General menu.
- Specify a file name and location.
- Click **Save**.

The configuration is saved as an XML file on to the PC. A JPG file is saved under the same name: this file contains a video image from each TrafiCam sensor connected and an overview of the assigned outputs.



Output overview:

TrafiCam	Output Relation:	Output 1	Output 2	Output 3	Output 4
1	OR	1	2	3	4
2	OR	5	6	7	8
3	OR	9	10	11	12
4	OR	13	14	15	16

Output overview with sensor images

Load a configuration to another interface

- Verify that you work in the interface mode of TrafiCam PC Tool.
- Click **Open...** from the General menu.
- Select the XML file.
- Click **Open**.
TrafiCam PC Tool displays the loaded configuration.
You modify the configuration first or you activate this configuration for the TrafiCam sensor:
- Click **Send Configuration** from the General menu.
After sending, TrafiCam PC Tool requests and displays the parameters of the activated configuration.
The system becomes operational.

Upgrade firmware

Upgrade the interface firmware

- Verify that you work in the interface mode of TrafiCam PC Tool.
- Click **Upgrade Firmware** from the Tools menu.
- Select the firmware file on the PC.
- Click **Open**.
The firmware upgrade process takes a few minutes. A pop-up window displays the status of the process.
- Click **Close**.
All outputs change status during the upgrade process.

To view product information, Select **About...** from the Tools menu. A pop-up window displays the product serial number, the hardware revision and the firmware version of the interface.

Upgrade the TrafiCam firmware

- Verify that you work in the sensor mode of TrafiCam PC Tool.
- Click **Upgrade Firmware** from the Tools menu.
- Select the firmware file on the PC.
- Click **Open**.
The firmware upgrade process takes a few minutes. A pop-up window displays the status of the process.
- Click **Close**.
TrafiCam remains operational during the upgrade process.

To view product information, Select **About...** from the Tools menu. A pop-up window displays the product serial number, the hardware revision, the firmware version and the lens type of the TrafiCam sensor.

Note: When upgrading a TrafiCam system, first upgrade the interface firmware and then upgrade the firmware of the TrafiCam sensor(s).

Change the colour of the zones

The display colour of the zones in TrafiCam PC Tool is set by default. Proceed as follows if you wish to change these colours:

- Verify that you work in the sensor mode of TrafiCam PC Tool.
- Select **Advanced Settings** from the Tools menu.
- Select **Zone Colours...**
- Click **Set Colour** to change the display colour of the zones.
- Click **OK**.

12. Hardware specification TrafiCam

CAMERA

CMOS, black & white, sensor 1/3", resolution 640x480, frame rate 30 FPS

LENS TYPE >	Wide angle	Narrow angle
Focal distance	3,0 mm	8,0 mm
Field of view - horizontal	95°	32°
Field of view - vertical	65°	22°
Field of view - diagonal	103°	39°

DIMENSIONS

L x H x W: 45 cm x 16 cm x 10 cm mounted vertically
41 cm x 18 cm x 10 cm mounted horizontally

Mass (including mounting bracket, excluding cable): 600 g
Sensor diameter: 10 cm

MATERIALS

Sensor
Front and back shell: polycarbonate
Mid section: fibre reinforced polyamide

Mounting bracket: fibre reinforced polyamide
Tube: aluminium

COMMUNICATION

RS485 service port for configuration

OUTPUTS

4 optical coupled dry contacts; I_{max} = 50 mA, P_{max} = 300 mW, U_{max} = 48 VDC

POWER SUPPLY VOLTAGE INPUT

12-26 V AC/DC

POWER CONSUMPTION

85 mA @ 12 V DC (1,2 W)
50 mA @ 24 V DC (1,2 W)

ENVIRONMENTAL

Temperature range: between - 34°C and +80°C
0 to 95% relative humidity, non-condensing

Housing: waterproof to IP67
Materials: weatherproof, UV-resistant

REGULATORY

EMC: Electromagnetic Compatibility - 204/108/EG
FCC: FCC part 15 Class A
NEMA: NEMA II Shock and vibration

13. Hardware specification 4TI

DIMENSIONS

L x H x W: 18,5 cm x 8,5 cm x 5 cm; DIN-rail clickable
Mass: 250 g

COMMUNICATION

USB between 4TI and PC
RS-485 between 4TI and TrafiCam

OUTPUTS

16 optical coupled dry contacts (detection output) + 1 optical coupled dry contact (error output)
(Pmax = 300 mW, Imax = 50 mA, Umax = 48 V DC)

POWER SUPPLY VOLTAGE INPUT

12-26 V AC/DC

POWER CONSUMPTION

120 mA @ 12 V DC (1,5 W)
60 mA @ 24 V DC (1,5 W)

REGULATORY

EMC: Electromagnetic Compatibility - 2004/108/EG
FCC: FCC part 15 Class A
NEMA: NEMA II Shock and vibration

14. Hardware specification 1TI

DIMENSIONS

L x H x W: 12,5 cm x 8,5 cm x 5 cm; DIN-rail clickable

Mass: 120 g

COMMUNICATION

USB between 1TI and PC

RS-485 between 1TI and TrafiCam

OUTPUTS

4 optical coupled dry contacts (detection output) + 1 optical coupled dry contact (error output)
(Pmax = 300 mW, I_{max} = 50 mA, U_{max} = 48 V DC)

POWER SUPPLY VOLTAGE INPUT

12-26 V AC/DC

POWER CONSUMPTION

78 mA @ 12 V DC (1,0 W)

42 mA @ 24 V DC (1,0 W)

REGULATORY

EMC: Electromagnetic Compatibility - 2004/108/EG

FCC: FCC part 15 Class A

NEMA: NEMA II Shock and vibration

15. Appendix

Appendix 1: Lens selection and camera positioning

2 types of TrafiCam sensors are available:

- **Wide angle lens**
Vehicle presence detection in the area close to the camera: detection of vehicles at the **stop bar**
- **Narrow angle lens**
Vehicle presence detection in the area more distant from the camera: **advance** detection of vehicles approaching the intersection



Wide angle lens



Narrow angle lens

Version	Focal distance	Angle of view			Detection area
		Vertical	Horizontal	Corner to corner	
Wide angle	3,0 mm	65°	95°	103°	0 to 25 m (0 - 80 ft)
Narrow angle	8,0 mm	22°	32°	39°	15 to 75 m (45 - 250 ft)

TrafiCam lens specifications

Guidelines for the sensor position

- **Height:** mount TrafiCam as high as possible.
- **Position** towards the road: position TrafiCam overhead if possible. If not, a side-fired position next to the fastest lane is recommended.
- **Orientation:** do not point TrafiCam at the horizon. Place the camera in a position that will have minimum exposure to direct sunlight.

The height and position of TrafiCam are important factors for minimizing occlusion. Occlusion occurs when a vehicle blocks out part of the field of view of TrafiCam. Please contact your supplier if you wish more information on how to reduce or avoid occlusion.

The detection area in relation to the camera height and the minimum detection distance

The image below illustrates the detection area, minimum and maximum detection distance. Presence detection zones should be positioned within the detection area.

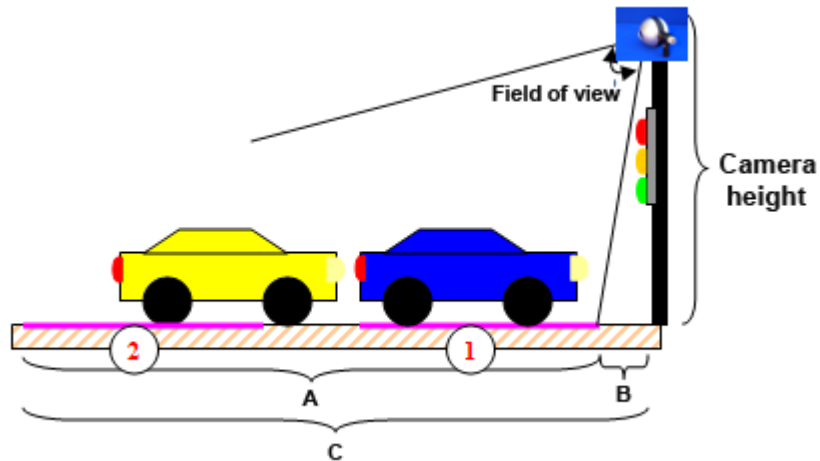

Detection area (A), minimum detection distance (B), maximum detection distance (C) and presence detection zones (1, 2)

Detection area, minimum and maximum detection distance are related to the camera height and the lens type.

TrafiCam wide angle lens

Camera height	Maximum detection distance			
Min. detection distance	0 m	1 m	2 m	3 m
3 m	6 m	25 m	25 m	25 m
4 m	8 m	20 m	25 m	25 m
5 m	10 m	20 m	25 m	25 m
6 m	12 m	21 m	25 m	25 m
7 m	15 m	23 m	25 m	25 m
8 m	17 m	24 m	25 m	25 m
9 m	19 m	25 m	25 m	25 m
10 m	21 m	25 m	25 m	25 m
11 m	23 m	25 m	25 m	25 m
12 m	25 m	25 m	25 m	25 m
13 m	25 m	25 m	25 m	25 m
14 m	25 m	25 m	25 m	25 m
15 m	25 m	25 m	25 m	25 m

Camera height	Maximum detection distance			
Min. detection distance	0 ft	3 ft	7 ft	10 ft
9 ft	20 ft	80 ft	80 ft	80 ft
13 ft	26 ft	66 ft	80 ft	80 ft
16 ft	33 ft	66 ft	80 ft	80 ft
20 ft	39 ft	69 ft	80 ft	80 ft
23 ft	49 ft	75 ft	80 ft	80 ft
26 ft	56 ft	79 ft	80 ft	80 ft
30 ft	62 ft	80 ft	80 ft	80 ft
33 ft	69 ft	80 ft	80 ft	80 ft
36 ft	75 ft	80 ft	80 ft	80 ft
39 ft	80 ft	80 ft	80 ft	80 ft
43 ft	80 ft	80 ft	80 ft	80 ft
46 ft	80 ft	80 ft	80 ft	80 ft
49 ft	80 ft	80 ft	80 ft	80 ft

Maximum detection distance for TrafiCam with a wide angle lens - metric (left) and imperial (right)

TrafiCam with 4TI or 1TI

TrafiCam narrow angle lens

Camera height	Maximum detection distance								
	6 m	7 m	8 m	10 m	12 m	15 m	18 m	20 m	25 m
3 m	37 m	75 m	75 m	75 m	75 m	75 m	75 m	75 m	75 m
4 m	19 m	29 m	50 m	75 m	75 m	75 m	75 m	75 m	75 m
5 m	15 m	20 m	28 m	62 m	75 m	75 m	75 m	75 m	75 m
6 m	-	17 m	22 m	38 m	75 m	75 m	75 m	75 m	75 m
7 m	-	16 m	20 m	30 m	48 m	75 m	75 m	75 m	75 m
8 m	-	-	-	26 m	38 m	75 m	75 m	75 m	75 m
9 m	-	-	-	24 m	33 m	57 m	75 m	75 m	75 m
10 m	-	-	-	23 m	31 m	48 m	75 m	75 m	75 m
11 m	-	-	-	-	29 m	43 m	66 m	75 m	75 m
12 m	-	-	-	-	28 m	40 m	57 m	75 m	75 m
13 m	-	-	-	-	27 m	37 m	52 m	66 m	75 m
14 m	-	-	-	-	-	36 m	49 m	60 m	75 m
15 m	-	-	-	-	-	35 m	46 m	56 m	75 m

Camera height	Maximum detection distance								
	20 ft	23 ft	26 ft	33 ft	39 ft	49 ft	59 ft	66 ft	82 ft
9 ft	121 ft	250 ft	250 ft	250 ft	250 ft	250 ft	250 ft	250 ft	250 ft
13 ft	62 ft	95 ft	164 ft	250 ft	250 ft	250 ft	250 ft	250 ft	250 ft
16 ft	49 ft	65 ft	91 ft	203 ft	250 ft	250 ft	250 ft	250 ft	250 ft
20 ft	-	55 ft	72 ft	124 ft	250 ft	250 ft	250 ft	250 ft	250 ft
23 ft	-	52 ft	65 ft	98 ft	157 ft	250 ft	250 ft	250 ft	250 ft
26 ft	-	-	-	85 ft	124 ft	250 ft	250 ft	250 ft	250 ft
30 ft	-	-	-	78 ft	108 ft	186 ft	250 ft	250 ft	250 ft
33 ft	-	-	-	75 ft	101 ft	157 ft	250 ft	250 ft	250 ft
36 ft	-	-	-	-	95 ft	141 ft	216 ft	250 ft	250 ft
39 ft	-	-	-	-	91 ft	131 ft	186 ft	250 ft	250 ft
43 ft	-	-	-	-	88 ft	121 ft	170 ft	216 ft	250 ft
46 ft	-	-	-	-	-	118 ft	160 ft	196 ft	250 ft
49 ft	-	-	-	-	-	114 ft	150 ft	183 ft	250 ft

Maximum detection distance for TrafiCam with a narrow angle lens - metric (top) and imperial (bottom) units

Appendix 2: Output wiring diagram

The TrafiCam device has 4 optical coupled dry contacts which serve as outputs. Via TrafiCam PC Tool you can set the outputs to open or close upon presence detection.

The scheme below illustrates the wiring diagram for the outputs.

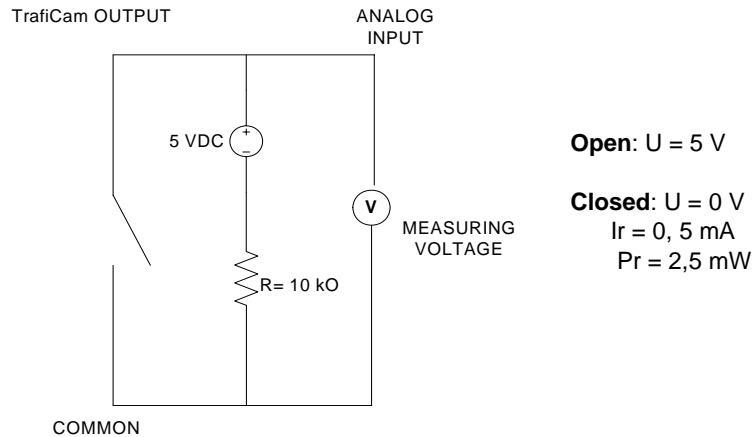

TrafiCam output wiring diagram

Appendix 3: Colour code of the cable wires

The cables for connection between the TrafiCam device and the interface are not included but can be supplied by Traficon. Hereafter you find the wire colour code of the cables which Traficon supplies.

Cable Wire Colour	use with 4TI/1TI (STP, UV-resistant, 4 wires + shielding)	use with TI (9 wires) (STP, UV-resistant, 10 wires + shielding)
BLUE	V-: GROUND	V-: GROUND
RED	V+: 10-24 VAC/DC	V+: 10-24 VAC/DC
GREEN	RS-485A	RS-485A
YELLOW	RS-485B	RS-485B
BLACK	-	COMMON OUTPUT GROUND
GREY	-	OUTPUT 1
PINK	-	OUTPUT 2
WHITE	-	OUTPUT 3
PURPLE	-	OUTPUT 4
BROWN	-	-

Colour code of the cable wires

Index

A

Advanced settings TrafiCam 23

C

Cable specifications 8

Connector pinout

1TI connector J5 7

1TI connector J7 7

4TI connector J1 (J3, J4, J5) 6

4TI connector J12 (J13) 6

TrafiCam connector CN1 5

F

Failsafe function 23

Filtering unwanted detection 24

Firmware upgrade 30

H

Hardware specification

1TI 33

4TI 32

TrafiCam 31

I

Installation

cable wire colour code 37

cables for connection 8

camera position guidelines 34

detection area and distance, camera height 35

mounting brackets and tube 8

output wiring diagram 37

stepwise process and illustration 10

Installation topology 9

Installation, software 14

Interface configuration 21

activation 22

assigning outputs 21

loading a configuration 30

saving to a PC 29

search for TrafiCam 21

Interface connectors, 1TI 7

Interface connectors, 4TI 6

Interface driver installation 14

Interface hardware 6

L

Live viewing 26

M

Maintenance 13

O

Outputs

assigning interface outputs 21

assigning TrafiCam outputs 18

interface, changing the output mode 21

output allocation file 29

setting the output relation 18

P

PC port for communication 14

Presence zones

adding or deleting a zone 18

assigning an output 18

defining the zone direction 18

delay and extend time 26

detection mode 17

editing the default presence zone 18

guidelines to edit the zones 20

stop detection mode 18

zone ID 18

R

Recall 23

detection recall 23

quality recall 23

T

TrafiCam LED deactivation 25

TrafiCam LED indicator code 5

TrafiCam PC Tool

basic functions 16

installation 14

work area basics 15

TrafiCam sensor

connectors 4

hardware 4

TrafiCam sensor selection 34

TrafiCam setup

activation 18

default factory setup 17

guidelines to edit the zones 20

learning cycle 19

loading a configuration 29

saving to a PC 28

V

Vehicle counting 27

Viewing detection 26

Viewing detection information display 26

Viewing product information 30